

## HEATS OF IMMERSION OF TITANIUM DIOXIDE PIGMENTS IN AQUEOUS SOLUTIONS

J. G. DAWBER, L. B. GUEST

*Department of Chemistry, North Staffordshire Polytechnic, Stoke-on-Trent (England)*

and R. LAMBOURNE

*Research and Development Department, Imperial Chemical Industries Ltd.,*

*Paints Division, Wexham Road, Slough, Bucks. (England)*

(Received February 11th, 1972)

### ABSTRACT

The heats of immersion in water and aqueous surfactant solutions of partially dried and conditioned titanium dioxide pigments were measured by a differential calorimetric method. The results were treated using a Hess's Law approach which allowed calculations to be made of the heat of adsorption of physically adsorbed water on the pigments. The results generally indicated an absence of capillary condensation of physically adsorbed water on the pigments.

### INTRODUCTION

Whenever the surface of a solid comes into contact with a non-reactive liquid or solution a thermal effect is observed. This effect is given several names; *heat of wetting*, *heat of immersion*, or the *Pouillet effect*. Boyd and Harkins<sup>1</sup> have used another term, namely, *heat of emersion* which refers to the reverse thermal process when liquid or solution is removed from the solid surface to leave a clean dry surface. In this paper we will use the term heat of immersion to describe the phenomenon and we will use the conventional system of indicating exothermic heat changes by a negative sign (which is not always adhered to in reporting heats of immersion).

Metal oxides usually possess high surface free energies so that they are readily wetted by water or aqueous solutions. It follows that the heat of immersion per gram of solid ( $\Delta H_i$ ) will be a function of the surface area of the solid, *i.e.*

$$\Delta H_i = A \Delta h_i \quad (1)$$

where  $A$  is the surface area per gram of solid, and  $\Delta h_i$  is the heat of immersion per unit area of oxide surface. Exceptions to this simple relationship can arise if the surface of the solid contains an extensive system of micropores and capillaries, which may give rise to time-dependent wetting properties and surface area values which differ

markedly according to the method of measurement. When complete wetting of the solid surface occurs, the measurement of heat of immersion provides a useful method of investigating the interaction of the solid surface with the liquid or solution into which the solid is immersed<sup>2</sup>.

Titanium dioxide (anatase and rutile) is an important material for the production of industrial pigments for the paint and printing industries. While the heats of immersion of titanium dioxide have been measured for a variety of systems<sup>3-8</sup>, in all cases the samples of solid were thoroughly dried at temperatures up to 500°C and outgassed at low pressures. Although these studies are of considerable academic importance they are of limited usefulness where systems of industrial interest are concerned, because the pigmentary forms of titanium dioxide are usually subjected to some form of surface modification to improve their dispersibility in paint or printing ink media and, in the case of paints, to minimise the effects of photo-initiated degradation of the polymer medium in the resultant film. Moreover, industrial practice precludes the vigorous drying of pigments so that in the industrial context it is important to obtain data on substrates that are contaminated with water. The surface treatments commonly employed involve the deposition of amphoteric oxides on the surface of the pigment. These surface coatings have been shown to be microporous by adsorption experiments<sup>9</sup> but in practice the pores are likely to be filled with water.

The treatment of such pigments at temperatures in the region 400–500°C significantly alters their surface properties and also seriously impairs their usefulness as pigments. The purpose of the present work was to investigate the heats of immersion of commercial rutile and anatase pigments which had been in equilibrium with water vapour under ambient laboratory conditions (nominally 25°C) and also superficially dried at 140°C for several hours at atmospheric pressure.

The pigments used in this work were a 'coated' rutile (the coating containing alumina, silica and zinc oxide) and an 'uncoated' anatase.

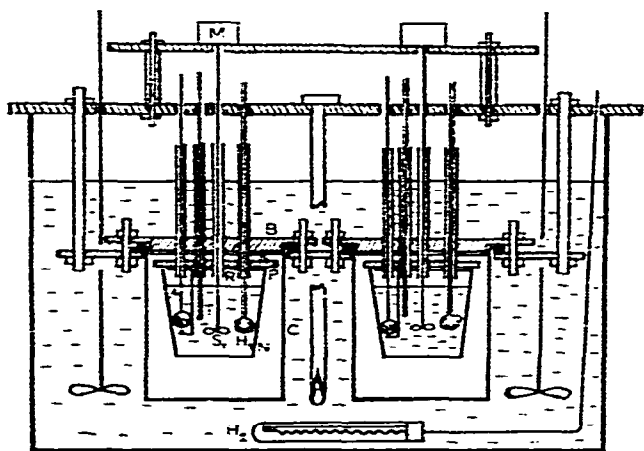

Fig. 1. Schematic diagram of the differential calorimeter used.

## EXPERIMENTAL

### *The calorimeter*

The calorimeter, which was of the differential type, is illustrated in Fig. 1. The immersion vessels were two highly polished nickel crucibles (N) of 75 cm<sup>3</sup> capacity. Each crucible was fitted with a Perspex lid (P) on the underside of which were polished brass radiation shields (R). The lids sealed onto the crucibles by means of Neoprene O-rings. Each lid contained a series of tubes through which the thermistors (T), heater (H<sub>1</sub>), stirrer (S<sub>1</sub>) and ampoule holder (A) were fitted.

Each of the immersion crucibles was suspended half an inch below a second Perspex disc (B) fitted with a brass radiation shield (R). These latter discs formed the lids of the air-jackets (C) which were made of copper. A Neoprene gasket formed a water-tight seal between these lids and the air-jackets. This system of metal containers remained adiabatic for a period of about 30 min, which was far in excess of the time involved in the immersion process. The equilibration time of the apparatus was about 4 h. The contents of each immersion vessel were stirred by nickel paddles (S<sub>1</sub>) driven by 200-r.p.m. synchronous motors (M) which were connected in parallel with the mains supply. The lids (B) of the air-jackets were bolted to a Paxolin plate, which in turn was bolted to part of the lid of a polystyrene water-thermostat. The temperature of the thermostat was controlled at  $25 \pm 0.01$  °C with a contact thermometer and a 60-watt electrical heater (H<sub>2</sub>) with a suitable relay circuit. The water thermostat was contained inside a large air-jacket fitted with a wooden lid.

Samples of pigment were contained in glass ampoules (15–20-mm diameter) carefully blown from 2-mm soda-glass tubing. The ampoules when fitted contained 1.0–1.5 g of solid. The ampoules and contents after drying were attached to a steel rod which contained a Teflon section for thermal insulation purposes. Ampoules were broken inside the calorimeters by gently pressing the bulb down onto metal spikes situated just below them.

The thermistors (T) used to measure the temperature changes in the immersion vessels had a nominal resistance of 2000 ohm and were matched to better than 1%. The thermistors formed two of the arms of a conventional Wheatstone bridge arrangement based upon a Pye precision resistance bridge with the ratio arms set at about 1000 ohm. The out-of-balance signal from the thermistors, which resulted from a temperature change following immersion of the pigments, was fed directly to a variable range potentiometric recorder. Normally, the recorder was set for 1 mV full-scale deflection with the zero adjusted to centre scale. The dependence of recorder reading upon thermal effect in the calorimeters was linear to about 1%.

The calibration heaters in each immersion vessel and the dummy heater were constructed from 26-SWG nichrome wire wound non-inductively around short glass rods, and had an approximate resistance of 5 ohm. They were placed in narrow glass tubes and embedded in paraffin wax. The circuit incorporating the calibration heaters and the dummy heater is shown in Fig. 2. Power was supplied to the heaters from two 12-volt accumulators connected in parallel, which were frequently recharged when

they were not in use by a 12-volt d.c. supply. Electrical power was supplied to the dummy heater for 2 h prior to an experiment involving the calibration heaters. The amount of current flowing during this period was indicated by a milli-ammeter, and the current could be adjusted using the variable resistance (VR1). The switch, K2, transferred power when required from the dummy heater to one of the calibration

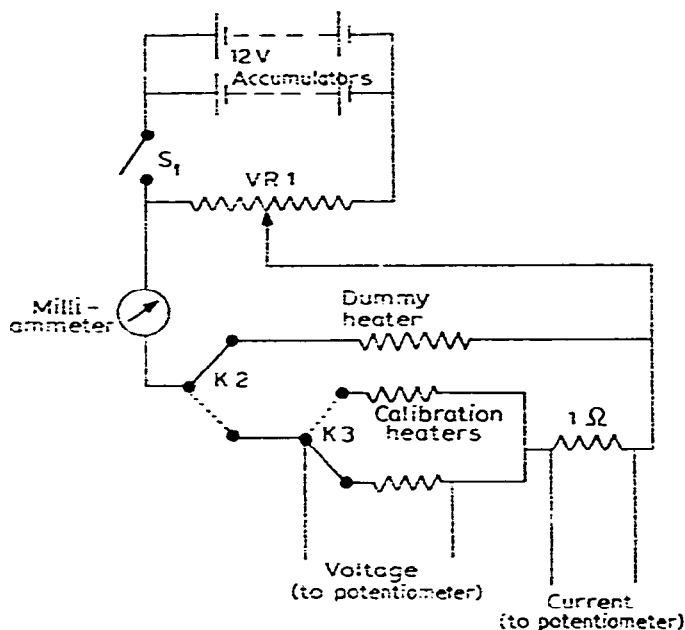

Fig. 2. Circuit diagram of the calibration heaters and the dummy heater.

heaters previously selected by the switch (K3). The actual current flowing through the heater was calculated from the measurement of the voltage drop across a standard 1 ohm. The voltage across the calibration heaters when they were in use was measured directly. Both these voltages were measured with a potentiometer capable of measuring to  $1 \mu\text{V}$ . Heating periods in the calibration experiments were timed with a stop-watch reading to  $\pm 0.1$  sec. The heating period was normally of about 3-min duration.

The differential temperature drift between the two immersion vessels when equilibrated was less than  $0.0001^\circ\text{C}$  per min and this was usually uniform over many minutes. The immersion experiments involved temperature changes of about  $0.015^\circ\text{C}$  over a period of about 3 min and hence the differential temperature drift was perfectly acceptable. Since the temperature rise in an immersion experiment was so small, the cooling correction applied to the results was only a very simple one. The exaggerated curve ABCDE in Fig. 3 represents a typical pre-reaction, reaction and post-reaction situation in a thermal experiment. The straight BCD of the reaction gave point F. A line perpendicular to the time axis was drawn through F to meet the pre-reaction curve

at G. The corrected temperature rise was then taken as FG. The corrections were so small that this method of cooling-correction was judged to be adequate.

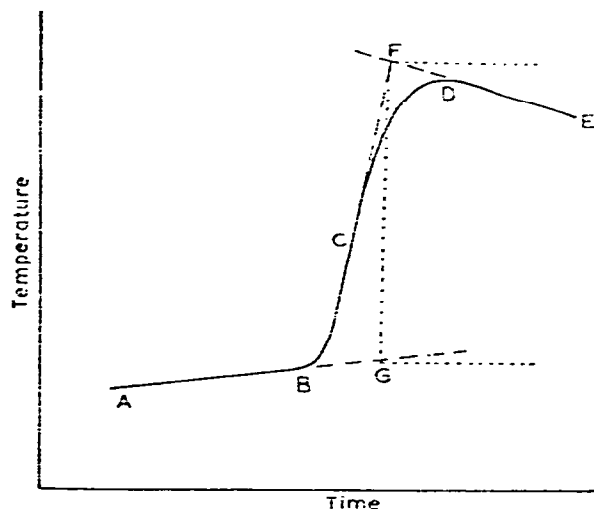

Fig. 3. Graphical method for the simple cooling correction.

The thermal effect produced by ampoule breaking was in the region of 0.5–0.6 J and a value of 0.6 J was subtracted from all experimentally measured heats of immersion.

#### *The pigments and their properties*

The surface areas of the rutile and anatase pigments were measured using a Strohlein area meter, after drying at 200°C in a stream of nitrogen for 3 h. Urwin<sup>9</sup> has shown that this single point method is suitable for measurements on commercial titanium dioxide pigments. The values obtained by this method were 11.1 m<sup>2</sup>·g<sup>-1</sup> for the rutile sample and 8.6 and 9.4 m<sup>2</sup>·g<sup>-1</sup> for the two samples of anatase. The surface area of the rutile measured by a complete BET method was 11.1 m<sup>2</sup>·g<sup>-1</sup>. Urwin<sup>9</sup> has concluded from surface area measurements that coated pigments, such as the coated rutile used in this work, are fairly porous. The internal area of coated pigments may account for up to half the total surface area and yet capillary condensation may be absent.

The composition of the coated rutile used in this work was ZnO, 1.02%; Al<sub>2</sub>O<sub>3</sub>, 2.15%; SiO<sub>2</sub>, 1.12%; the remainder being titanium dioxide and water. The water adsorbed on the pigments was measured by thermogravimetric analysis (TG) and also by Karl–Fischer titrations. The results are summarised in Table I. The TG results indicated that the rutile possessed more adsorbed water than the anatase and was much more difficult to remove. This may well be due to the porous nature of the rutile. The Karl–Fischer results for the rutile also supported this view.

If an approximate molecular area of 10<sup>-19</sup> m<sup>2</sup> is taken for the water molecule, then the anatase would possess approximately a monolayer of adsorbed water and

the rutile would possess the equivalent of approximately six molecular layers of water. After drying at 140°C for several hours the anatase may be regarded as having been dehydrated and the rutile may be regarded as still possessing approximately two molecular layers of adsorbed water. Recent infrared studies<sup>10</sup> on pure rutile suggest two types of surface site for adsorption of water as molecular water and as hydroxyl

TABLE I  
PROPERTIES OF THE TITANIUM DIOXIDE PIGMENTS

<i>Property measured</i>	<i>Anatase</i>	<i>Coated rutile</i>
Surface area (m <sup>2</sup> .g <sup>-1</sup> )	8.6 and 9.4	11.1
Water content (mg of H <sub>2</sub> O per g of pigment)		
(a) <i>TG method</i>		
(i) 4 h at 140°C	3.5	13.2
(ii) 1.5 h at 550°C	3.9	19.4
(b) <i>Karl-Fischer method</i>		
(i) dioxan solvent	3.5	8.2
(ii) methanol solvent	3.4	11.8

ions. In pure rutile the (100), (101) and (110) crystal faces account for about 98% of the external surface of the solid. The (100) and (101) faces appear to adsorb molecular water as a ligand coordinated to Ti<sup>4+</sup> surface ions. The (110) crystal face adsorbs water dissociatively leading to formation of surface hydroxyl ions. In the rutile used in this work the surface is rather different although the water may well be adsorbed in a similar way.

## RESULTS

In the subsequent discussion the pigments dried at 140°C for several hours will be referred to as *dried* pigments (S<sub>d</sub>) and the pigment conditioned at room temperature as *conditioned* pigment (S<sub>c</sub>). The heats of immersion of oven-dried and conditioned samples of the anatase and the coated rutile were measured in water and 0.1 M solutions of propionic acid (HPr), sodium lauryl sulphonate (SLS), sodium benzene sulphonate (SBS), cetyl trimethyl ammonium bromide (CTAB) and 0.01 M solutions of potassium stearate (KSt) and potassium oleate (KOI). The results are presented in Tables II and III in terms of heat change per gram of pigment and heat change per unit surface area of pigment. A negative sign indicates an exothermic heat of immersion.

The heats of immersion per unit area for the dried pigments in water are -0.51 J·m<sup>-2</sup> for rutile and -0.26 J·m<sup>-2</sup> for anatase. The literature values for immersion of pure titanium dioxide in water vary considerably but in general they lie between -0.2 and -0.6 J·m<sup>-2</sup> for solids dehydrated at 150°C. The value of heat of immersion of rutile in water is higher than that for anatase, which is probably due to

the formation of multi-molecular layers of water on the rutile and only a monolayer of water on the anatase on immersion of the oven-dried pigments.

TABLE II  
HEATS OF IMMERSION OF RUTILE IN AQUEOUS SYSTEMS AT 25°C

System	Dried pigment ( $\Delta H_{id}$ and $\Delta H_{idaq}$ )		Conditioned pigment ( $\Delta H_{ic}$ and $\Delta H_{icaq}$ )	
	( $J.g^{-1}$ )	( $J.m^{-2}$ )	( $J.g^{-1}$ )	( $J.m^{-2}$ )
Water	-5.70	-0.51	+1.3	+0.12
KSt(0.01M)	-8.2	-0.74	-1.35	-0.12
HPr(0.1M)	-9.30	-0.84	-2.65	-0.24
KOl(0.01M)	-8.70	-0.79	-1.35	-0.12
SLS(0.1M)	-6.50	-0.58	-1.35	-0.12
SBS(0.1M)	-7.25	-0.65	-1.25	-0.11
CTAB(0.1M)	-8.25	-0.74	-1.10	-0.10

TABLE III  
HEATS OF IMMERSION OF ANATASE IN AQUEOUS SYSTEMS AT 25°C

System	Dried pigment ( $\Delta H_{id}$ and $\Delta H_{idaq}$ )		Conditioned pigment ( $\Delta H_{ic}$ and $\Delta H_{icaq}$ )	
	( $J.g^{-1}$ )	( $J.m^{-2}$ )	( $J.g^{-1}$ )	( $J.m^{-2}$ )
Water	-2.4	-0.26	-0.50	-0.05
KSt(0.01M)	-2.2	-0.24	-0.30	-0.03
	-2.0	-0.22		
HPr(0.1M)	-1.9	-0.21	-0.40	-0.04
KOl(0.01M)	-2.60	-0.29	-0.90	-0.10
	-2.80	-0.31	-1.00	-0.11
SLS(0.1M)	-2.9	-0.32	-1.00	-0.11
	-3.15	-0.35		
SBS(0.1M)	-2.05	-0.22 <sub>s</sub>	-0.25	-0.03
CTAB(0.1M)	-1.8 <sub>s</sub>	-0.20 <sub>s</sub>	-1.30	-0.15

#### DISCUSSION

The heat of immersion ( $\Delta H_{id}$ ) of a *dry* solid in a pure liquid (l) may be regarded as the heat change in the reaction

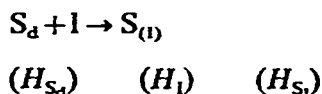

If the  $H$  terms are enthalpies (not necessarily molar enthalpies) the heat of immersion will be given by

$$\Delta H_{id} = H_{S_l} - H_{S_d} - H_l \quad (2)$$

The heat of immersion in a pure liquid of solid conditioned with water vapour ( $\Delta H_{ic}$ ) may be regarded as the heat change in the reaction

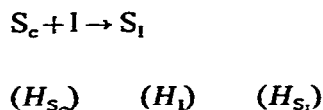

so that

$$\Delta H_{ic} = H_{S_l} - H_{S_c} - H_l \quad (3)$$

These two equations assume that the dispersion of the solid is identical whether prepared from dried solid or conditioned solid.

If the conditioned solid  $S_c$  may be formed from the dry solid  $S_d$  by adsorption of  $n_1$  moles of vapour  $V$  from the liquid  $l$ , then we may write



The heat change for this process corresponds to the heat of adsorption ( $\Delta H_{SV}$ ) of vapour onto 1 g of dry solid. The relationship between two heats of immersion  $\Delta H_{id}$  and  $\Delta H_{ic}$ , and  $\Delta H_{SV}$  can be obtained by the application of Hess's law to the formation of dispersions from dry solid and conditioned solid. The equations will initially be developed for immersion of solids in a pure liquid, which in this work was water. The theory will then be extended to immersion of solids into solutions, which in this work were aqueous solutions of surfactants.

#### *Case A. Immersion of pigment into a pure liquid*

In this work the pure liquid is water and the vapour involved is water vapour although the theory applies to any other system. The method of derivation follows that used by Gregg and Sing<sup>11</sup>. The formation of pigment dispersions in water is considered first from dry solid ( $S_d$ ) and then from conditioned solid ( $S_c$ ) and the two methods are then compared.

*Method I. Using dry solid ( $S_d$ ).* — In this method  $n$  moles of vapour are condensed and then the dry solid is immersed in the resulting liquid



where  $L_v$  is the molar heat of vaporisation.



where  $\Delta H_{id}$  is the heat of immersion per gram of dry solid in pure liquid. Addition of these two equations gives the process

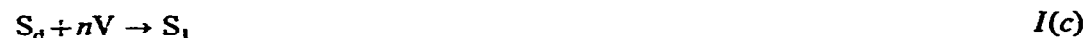

the heat change ( $\Delta H$ ) for which is given by

$$\Delta H = nL_v + \Delta H_{id} \quad (4)$$



*Method II. Using conditioned solid (S<sub>c</sub>).* — In this method the conditioned solid S<sub>c</sub> is formed by adsorption of n<sub>1</sub> moles of vapour onto dry solid S<sub>d</sub>. The remaining n - n<sub>1</sub> moles of vapour are then condensed to form liquid and the conditioned solid is then immersed in this liquid to form the dispersion (S<sub>1</sub>).

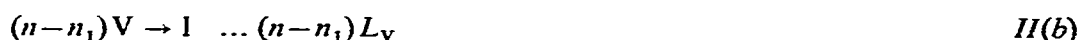

Addition of these equations gives the process



the heat change for which is

$$\Delta H = \Delta H_{SV} + (n - n_1) L_v + \Delta H_{ic} \quad (5)$$

Provided that the state of the final pigment dispersion is the same by Method I as by Method II then processes I(c) and II(d) are identical, and the heat changes in Eqns. (4) and (5) are the same. Thus one obtains the equation

$$\Delta H_{id} - \Delta H_{ic} = \Delta H_{SV} - n_1 L_v \quad (6)$$

Thus the difference in heats of immersion of dry and conditioned pigment is simply related to the heat of adsorption of vapour onto the dry solid ( $\Delta H_{SV}$ ) and the heat of vaporisation of the liquid ( $L_v$ ). The term  $\Delta H_{SV} - n_1 L_v$  is the *net integral heat of adsorption*. The amount of adsorbed water n<sub>1</sub> (*i.e.* the difference between S<sub>c</sub> and S<sub>d</sub>), may be obtained from the TG data. This enables  $\Delta H_{SV}$  to be calculated using Eqn. (6). If n<sub>1</sub> refers to 1 g of solid, then  $\Delta H_{SV}$  will also refer to 1 g of solid.

#### *Case B. Immersion of pigment into a solution*

In this case the heat of solution of the solute and the heat of adsorption of the solute onto the pigment are included in the derivation of the equations. The thermal effect of dilution of the solution due to the adsorption of the solute on the pigment is assumed to be very small and is ignored.

*Method III. Using dry solid (S<sub>d</sub>).* — The sequence of operations in forming the dispersion in a solution of a solute A is as follows: (i) condensation of solvent (water) vapour to form liquid (l); (ii) dissolution of solute, A<sub>s</sub>, in the water to form solution, A<sub>aq</sub>; and (iii) immersion of dry solid, S<sub>d</sub>, into the solution A<sub>aq</sub>.

When the pigment is immersed in the solution, not only will solvent be adsorbed as in Method I, but adsorption of solute will also occur. If the solute is adsorbed on some sites that would have been occupied by water molecules had the immersion been in pure water, then the heat change due to the interaction of water with the pigment will be less than  $\Delta H_{id}$  (Case A) by an amount of heat equivalent to the water displaced from the surface by the adsorbed solute. This heat of interaction of water *from the*

solution with the pigment will be represented as  $\Delta H'_{id}$ . The heat change due to the adsorption of solute will be a function of the amount of solute adsorbed,  $n'_A$ .

The sequence of operations for the formation of the pigment dispersion ( $S_{aq}$ ) in an aqueous solution is as follows:



(where  $\Delta H_s$  is the molar heat of solution of solute A in water)

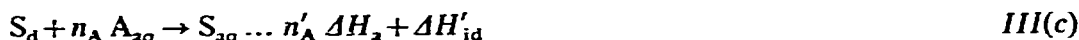

(where  $\Delta H_a$  is the molar heat of adsorption of solute per gram of pigment). Thus for the reaction

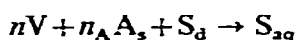

the overall heat change will be given by

$$\Delta H = nL_v + n_A \Delta H_s + n'_A \Delta H_a + \Delta H'_{id} \quad (7)$$

The measured heat of immersion of the dry pigment in the aqueous solution is  $\Delta H_{idaq}$  and is given by the heat change of reaction *III(c)*, namely

$$\Delta H_{idaq} = n'_A \Delta H_a + \Delta H'_{id} \quad (8)$$

*Method IV. Using conditioned solid ( $S_c$ ).* — The sequence of operations in forming the dispersion of the conditioned pigment in a solution of solute A is as follows: (i) formation of conditioned solid from dry solid ( $S_d$ ) and water vapour; (ii) formation of liquid water from the remaining vapour; (iii) dissolution of solute  $A_s$  in the water to form the solution  $A_{aq}$  (here it is assumed that the concentration difference between this solution and that produced in stage *III(b)* is negligible); and (iv) immersion of the conditioned solid ( $S_c$ ) into the solution  $A_{aq}$ .

Once again solute will be adsorbed onto the pigment in process *IV(d)* and this will be accompanied by a further adsorption (or even desorption) of water. The heat change due to further adsorption of water from the solution will be different from  $\Delta H_{id}$ ,  $\Delta H'_{id}$ , and  $\Delta H_{ic}$ ; and will be represented here as  $\Delta H'_{ic}$ . The heat change due to adsorption of solute will again depend on the amount adsorbed,  $n'_A$ , and it is assumed that this is the same amount as in Method *III* given above.

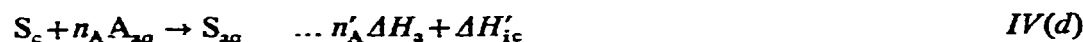

The measured heat of immersion of the conditioned pigment in the aqueous solution  $A_{aq}$  is the heat change in reaction  $IV(d)$  and will be represented by  $\Delta H_{icaq}$ . Thus

$$\Delta H_{icaq} = n'_A \Delta H_a + \Delta H'_{ic} \quad (9)$$

Addition of reactions  $IV(a)$  to  $IV(d)$  gives the reaction

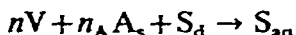

the overall heat change for which is given by

$$\Delta H = \Delta H_{SV} + (n - n_1)L_V + n_A \Delta H_s + n'_A \Delta H_a + \Delta H'_{ic} \quad (10)$$

If the state of the pigment dispersion is the same from Method *III* as from Method *IV*, then the values of  $\Delta H$  and Eqns. (7) and (10) should be identical yielding the expression

$$\begin{aligned} \Delta H'_{id} - \Delta H'_{ic} &= \Delta H_{SV} - n_1 L_V \\ &= \Delta H_{idaq} - \Delta H_{icaq} \end{aligned} \quad (11)$$

Eqn. (11) shows that the difference in *heats of interaction* of water with conditioned pigment and dry pigment in the solution  $A_{aq}$  and the differences in heats of immersion are equal to the *net integral heat of adsorption of solvent vapor onto the dry pigment*. Eqn. (11) is to be compared with Eqn. (6) where it was shown that the net integral heat of adsorption of water vapour is given by the difference in the *heats of immersion* of dry and conditioned pigments in pure water.

The value of  $n_1$ , the amount of adsorbed water on the pigment, or more correctly the difference between  $S_d$  and  $S_c$ , may be calculated from the thermogravimetric data, and is  $7.3 \times 10^{-4}$  mole·g<sup>-1</sup> for the rutile and  $1.94 \times 10^{-4}$  mole·g<sup>-1</sup> for the anatase. Thus  $\Delta H_{SV}$ , the heat of adsorption of water vapour onto the dry pigments may be calculated from the heats of immersion using Eqns. (6) and (11). A value of  $L_V$  for water of  $-43.8$  kJ·mole<sup>-1</sup> (25°C) has been used. The values of  $\Delta H_{SV}$  for rutile are given in Table IV, and those for anatase are given in Table V. The values, when calculated per gram of pigment, are much higher for the rutile pigment than the anatase pigment. However, when the results are calculated per mol of water adsorbed per gram of pigment, then the values of  $\Delta H_{SV}$  for both pigments are remarkably

TABLE IV  
CALCULATED VALUES OF HEAT OF ADSORPTION  
OF WATER ( $\Delta H_{SV}$ ) ON RUTILE

System	H <sub>2</sub> O	KSt	HPr	KOI	SLS	SBS	CTAB
$\Delta H_{SV}$ (J·g <sup>-1</sup> )	-38.9	-38.7	-39.1	-39.3	-37.1	-37.9	-39.2
$\Delta H_{SV}$ (kJ·g <sup>-1</sup> per mole of H <sub>2</sub> O)	-53.3	-53.0	-53.6	-53.8	-50.8	-51.9	-53.7

similar being in the region of  $53 \text{ kJ}\cdot\text{mol}^{-1}$ . This value is only slightly higher than the heat of vaporisation of water, which suggests that the adsorbed water which was removed at  $140^\circ\text{C}$  was only bound to the surface of both pigments by van der Waal's forces. Despite the fact that the surfaces of the coated rutile and uncoated anatase are completely different, the rutile being rather more porous than the anatase, the very similar molar  $\Delta H_{SV}$  values for both pigments suggests little or no capillary condensation of water on the conditioned rutile pigment.

TABLE V  
CALCULATED VALUES OF HEAT OF ADSORPTION  
OF WATER ( $\Delta H_{SV}$ ) ON ANATASE

<i>System</i>	<i>H<sub>2</sub>O</i>	<i>KSt</i>	<i>HPr</i>	<i>KOl</i>	<i>SLS</i>	<i>SBS</i>	<i>CTAB</i>
$\Delta H_{SV}$ ( $\text{J}\cdot\text{g}^{-1}$ )	-10.4	-10.3	-10.0	-10.3	-10.5	-10.3	-9.1
$\Delta H_{SV}$ ( $\text{kJ}\cdot\text{g}^{-1}$ per mole of $\text{H}_2\text{O}$ )	-53.6	-53.1	-51.5	-53.6	-54.1	-53.7	-46.9

The molar values of  $\Delta H_{SV}$  for the rutile in sodium lauryl sulphate and sodium benzene sulphonate solutions show some variation from the majority of the results and similarly the value for anatase in cetyl trimethyl ammonium bromide solution is anomalous. A possible explanation for these three differences is that the two immersion processes, that is starting with dried pigment and conditioned pigment, do not lead to the same equilibrium dispersion state for these three systems, within the period of time involved in the immersion experiments. In any case, these three systems were found to give unusual viscosity behaviour when the rheology of the pigment dispersions was studied.

A comparison of Eqns. (6), (8), (9) and (11) shows that

$$\Delta H_{idaq} - \Delta H_{icaq} = \Delta H_{id} - \Delta H_{ic}$$

or

$$\Delta H_{idaq} = \Delta H_{id} - (\Delta H_{ic} - \Delta H_{icaq}) \quad (12)$$

Thus from measurements of the heats of immersion of the dried pigments in water and the heats of immersion of the conditioned pigments in both water and a given solution ( $A_{aq}$ ), it should be possible to calculate the heat of immersion of the dried pigments ( $\Delta H_{idaq}$ ) in the solution  $A_{aq}$ . These values may then be compared with the experimentally determined values in order to test the theoretical approach adopted here. The comparisons between the calculated and measured heats of immersion are made in Tables VI and VII and the agreement in most cases is reasonable. The exceptions are predictably the values for rutile pigment in sodium lauryl sulphate and sodium benzene sulphonate solutions and anatase pigment in cetyl trimethyl ammonium bromide solution, for the probable reasons discussed above. Nevertheless, the agreement in the other cases is sufficiently good to give some confidence in the

experimental results and also in the theoretical treatment of the immersion process in terms of a Hess's law approach.

TABLE VI

COMPARISON OF CALCULATED AND MEASURED HEATS OF IMMERSION OF DRIED RUTILE

<i>System</i>	<i>KSt</i>	<i>HPr</i>	<i>KOI</i>	<i>SLS</i>	<i>SBS</i>	<i>CTAB</i>
$\Delta H_{\text{idaq}}$ ( $\text{J}\cdot\text{g}^{-1}$ )						
calculated	-8.35	-9.65	-8.35	-8.35	-8.25	-8.10
measured	-8.20	-9.85	-8.70	-6.50	-7.25	-8.25

TABLE VII

COMPARISON OF CALCULATED AND MEASURED HEATS OF IMMERSION OF DRIED ANATASE

<i>System</i>	<i>KSt</i>	<i>HPr</i>	<i>KOI</i>	<i>SLS</i>	<i>SBS</i>	<i>CTAB</i>
$\Delta H_{\text{idaq}}$ ( $\text{J}\cdot\text{g}^{-1}$ )						
calculated	-2.40	-2.20	-2.90 -2.80	-2.90	-2.15	-3.25
measured	-2.40	-2.20 -2.00	-2.80 -2.60	-2.90 -3.15	-2.05	-1.85

In the case of the rutile pigment it is possible that the solute is adsorbed on top of a full complement of adsorbed water when the dried pigment is immersed in a solution. The exceptions, as discussed above, are the solutions of sodium lauryl sulphate and sodium benzene sulphonate in which the heats of immersion are slightly lower than expected. Perhaps these two solutes enter markedly into competition with the water for sites on the dry rutile pigment when it is immersed in their solutions.

Cetyl trimethyl ammonium bromide exerted a very powerful flocculating effect on the anatase dispersion and it is possible that the extent of flocculation is different starting with dry anatase than with conditioned anatase. Indeed, the theoretical treatment in this work has assumed that in a given solution the extents of flocculation of a pigment dispersion are the same starting with dry and conditioned pigment. While this seems to be the case for most of the systems studied in this work, it cannot always be the case for every solute.

#### REFERENCES

- 1 G. E. Boyd and W. D. Harkins, *J. Amer. Chem. Soc.*, 64 (1942) 1190 and 1195.
- 2 J. J. Chessick and A. C. Zettlemoyer, *Advan. Catal. Relat. Subj.*, 11 (1959) 263.
- 3 W. D. Harkins, *The Physical Chemistry of Surface Films*, Reinhold Publishing Corp., New York, 1952, p. 54.

- 4 A. C. Zettlemoyer, G. J. Young, J. J. Chessick and F. H. Healey, *J. Phys. Chem.*, 57 (1953) 650.
- 5 J. J. Chessick, A. C. Zettlemoyer, F. H. Healey and G. J. Young, *J. Phys. Chem.*, 58 (1954) 887.
- 6 J. J. Chessick, A. C. Zettlemoyer, F. H. Healey and G. J. Young, *Can. J. Chem.*, 33 (1955) 251.
- 7 W. H. Wade and N. Hakerman, *J. Phys. Chem.*, 65 (1961) 1681.
- 8 T. Omori, J. Impai, N. Nahao and T. Morimoto, *Bull. Chem. Soc. Jap.*, 42 (1969) 943 and 2198.
- 9 D. Urwin, *J. Oil Colour Chem. Ass.*, 52 (1969) 697.
- 10 J. A. Hockey, *Trans. Faraday Soc.*, 67 (1971) 2669 and 2679.
- 11 S. J. Gregg and K. S. W. Sing, *Adsorption, Surface Area and Porosity*, Academic Press, London, 1967, p. 297.